

NOM-19-S

GRAB N' GO SLIM VERTICAL OPEN MERCHANDISER

Ideal for cafés, convenience stores and supermarkets

NEW AIR
REFRIGERATION



FEATURES

Pull-down night curtain



Tempered glass

3 adjustable stainless steel shelves

Price tag channels



Stainless steel exterior & interior

Digital tempered control

Casters (with front brakes)

LED lighting on top of unit and
under each shelf

SPECIFICATIONS

Capacity (Cu. ft)	7.8
Capacity (Litres)	220
Exterior Unit Dimensions (in)	19.5" (w) x 27.5" (d) x 68.75" (h)
Interior Dimensions (in)	18.25" (w) x 18.25" (d) x 42" (h)
Packaging Dimensions (in)	21.5" (w) x 29.5" (d) x 68.75" (h)
Net/Gross Weight (lbs)	210/247
Adjustable Shelves	3
Shelf Dimension	17.5" (w) x 10.75" (d)
Shelf Capacity (lbs)	22lbs
Casters	4 (2 with brakes)
Temperature	(2°C) - (10°C)
Ambiant Temperature	<27°C
Ambiant Humidity	<60%
Refrigerant (CFC-Free)	R290
Input Power (W)	1135
Voltage	110V/60Hz
Amperage	11.8
Plug Type	NEMA 5-15P

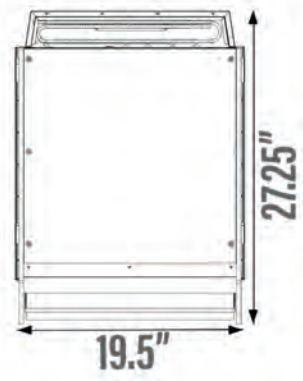
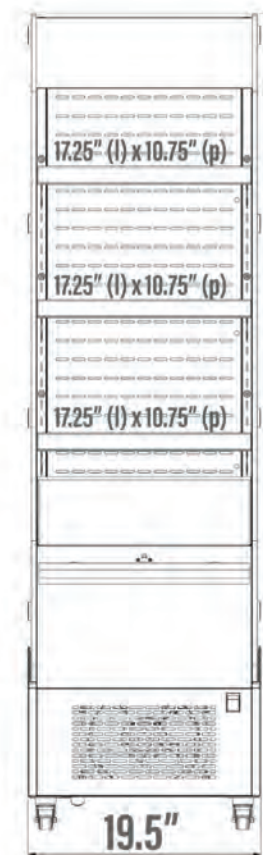
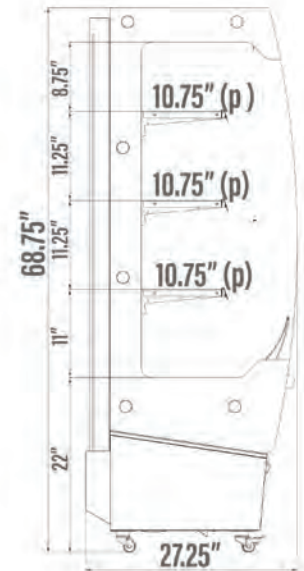

NEW AIR

*Design and specifications can change without prior notice for product improvement

CUSTOMER SUPPORT



1-800-567-3620



NEWAIRREFRIGERATION.CA

