

PREMIUM SERIES

NOM-36-HTS

HEATED GRAB 'N GO OPEN MERCHANDISER

Ideal for restaurants, cafés, convenience stores and supermarkets

NEW AIR
REFRIGERATION



FEATURES

Standard night curtain



Warm tone LED lighting on the top of unit and under each shelf

The temperature of each shelf is independently controlled



Brushed black stainless steel exterior

Digital temperature control with separate switch



4 sturdy wheels with two support legs at the front

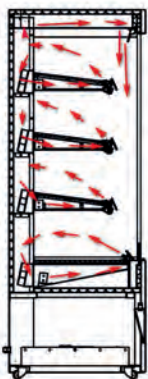

AIR CIRCULATION: Hot air circulates around each shelf surface keeping products warm.

These appliances are designed to keep precooked foods at a temperature of 65°C to 71°C (149°F to 160°F).

SPECIFICATIONS

Capacity (Cu. ft)	6.04	
Capacity (Litres)	171	
Exterior Unit Dimensions (in)	36" (w) x 35" (d) x 53.5" (h)	
Interior Dimensions (in)	33.25" (w) x 23" (d) x 28" (h)	
Packaging Dimensions (in)	38" (w) x 39" (d) x 57" (h)	
Net Weight (lbs)	125/276	
Night Curtain	Yes	
Casters	4	
Front Support Leg	2	
Shelves	2	
Shelf Dimensions (in)	32.5" (w) x 11" (d) (top) 32.5" (w) x 14.75" (d) (middle) 32.5" (w) x 22" (d) (bottom)	
Shelf Capacity (lbs) (lbs)	80	
Temperature	(65°C) - (71°C)	
Voltage	208V/60Hz/1PH	240V/60Hz/1PH
Amperage	13.70	15.83
Plug Type	NEMA 6-30P	

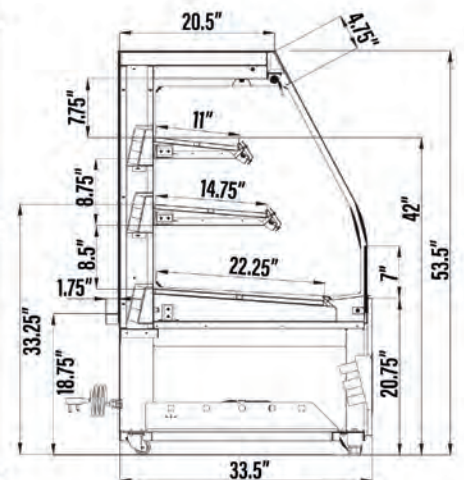
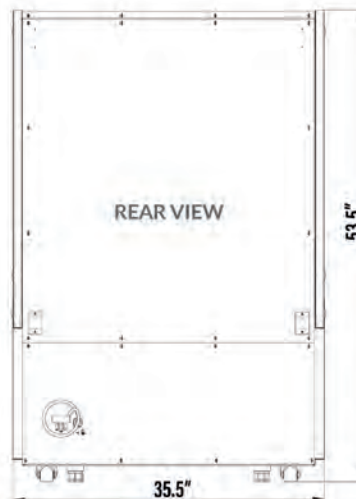
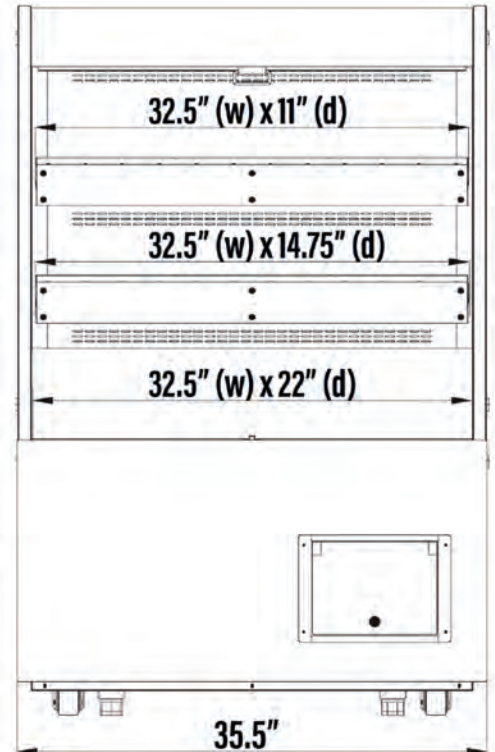

CUSTOMER SUPPORT



1-800-567-3620



NEWAIRREFRIGERATION.CA



NEW AIR

*Design and specifications can change without prior notice for product improvement