

NPT-029-SA

REFRIGERATED SALAD/SANDWICH PREP TABLE

Ideal for restaurants, cafeterias & food processing spaces

NEW AIR



FEATURES

Stainless steel interior and exterior

Rear digital controller

Back mounted compressor

Self-closing doors with stay open feature

Adjustable heavy duty shelves

Clear plastic 1/6 pans included

14.5" deep cutting board



SPECIFICATIONS

Capacity (Cu. ft)	6.56
Capacity (Liters)	185.75 L
Exterior Dimensions (in)	28 3/4" x 33 1/8" x 43 5/8"
Interior Dimensions (in)	25" x 20" x 23"
Net Weight (kg/lbs)	91.62 kg / 202 lbs
Door(s)	1
Temperature Range (°C)	0.5 TO 5°C
Ambiant Temperature	25°C
Ambiant Humidity	55%
Refrigerant (CFC-Free)	R290
Amperage (A)	2 A
Voltage (V)	115V / 60Hz
Plug Type	NEMA 5-15P

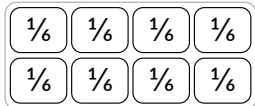
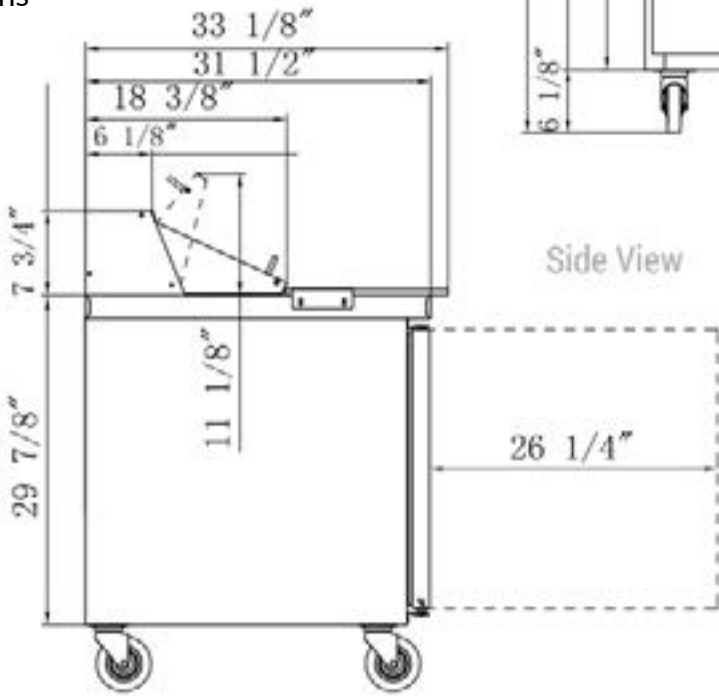

8 x 1/2" Pans



*Design and specifications may change without prior notice for product improvement

CUSTOMER SUPPORT



1-800-567-3620



NEWAIRREFRIGERATION.CA

