

NSF-050-H

STAINLESS STEEL REACH-IN FREEZER

NEW AIR
REFRIGERATION



Ideal for commercial kitchens, restaurants & food processing spaces



REVERSIBLE HINGE
FEATURE

FEATURES

Dixell™ digital temperature controller & on/off switch



Self-closing doors with stay open feature

Adjustable epoxy coated wire shelves



Stainless steel interior & exterior

Heavy duty caster with front brakes



Interior LED lighting



T-RACK FITS 18" x 26" PANS

Food rack insert can be used with all refrigerator & freezer sizes

Product code: TRACK-1418-SS

SPECIFICATIONS

Capacity (Cu. ft)	17.79
Capacity (Litres)	504
Exterior Unit Dimensions (in)	27.5" (w) x 32.5" (d) x 81.5" (h)
Interior Dimensions (in)	21.75" (w) x 27.5" (d) x 48.75" (h)
Packaging Dimensions (in)	29" (w) x 35" (d) x 83" (h)
Net/Gross Weight (lbs)	287/388
Doors	1
Adjustable Shelves	4
Shelf Dimensions	21" (w) x 24.5" (d)/per shelf
Casters	4 (2 with brakes)
Temperature	(-18°C) - (-22°C)
Ambiant Temperature	<38°C
Ambiant Humidity	65%
Refrigerant (CFC-Free)	R290
Input Power (W)	750
Voltage	115V/60Hz
Amperage	9.5
Plug Type	NEMA 5-15P

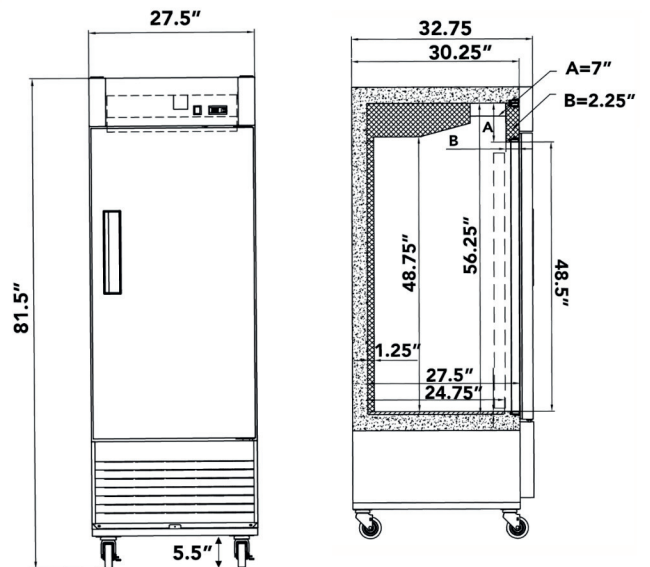
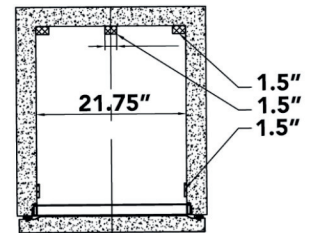

NEMA 5-15P



Intertek



CUSTOMER SUPPORT



1-800-567-3620



NEWAIRREFRIGERATION.CA



NEW AIR

*Design and specifications can change without prior notice for product improvement