

# NUF-029-SS

## CONGÉLATEURS SOUS-COMPTOIR

Idéal pour les restaurants, les cafétérias et les espaces de transformation des aliments

**NEW AIR**  
REFRIGERATION



### CARACTÉRISTIQUES

Contrôle numérique de la température  
Dixell™



Intérieur et extérieur en acier  
inoxydable



Etagère ajustable en époxy

Portes à fermeture automatique avec  
fonction de maintien ouvert

Compresseur monté à l'arrière

Roulettes



### CARACTÉRISTIQUES OPTIONNELLES



Étagères supplémentaires



Roulettes à profil bas

# SPÉCIFICATIONS

Capacité (pi <sup>3</sup> )	6.99
Capacité (litres)	198
Dimensions extérieures (po)	29.25" (l) x 31.5" (p) x 36" (h)
Dimensions intérieures (po)	25" (l) x 27" (p) x 25" (h)
Dimensions de l'emballage (po)	30.5" (l) x 33.25" (p) x 39.5" (h)
Poids net (kg / lb)	158
Portes	1
Étagères ajustables	1
Dimension de l'étagère (po)	24" (l) x 16.25" (p)
Roulettes	4
Température (°C)	(-18°C) - (-22°C)
Humidité ambiante	≤ 55%
Température ambiante	≤ 30°C
Réfrigérant (sans CFC)	R290
Voltage (V)	115V / 60Hz
Ampérage (A)	2.3
Puissance d'entrée (W)	550W
Type de prise	NEMA 5-15P

 THORINOX



DOUBLE OVERSHELF WITH ADJUSTABLE MIDDLE SHELF

Double overshelf can be used with all prep tables  
Product code: TDO5-XX-SS

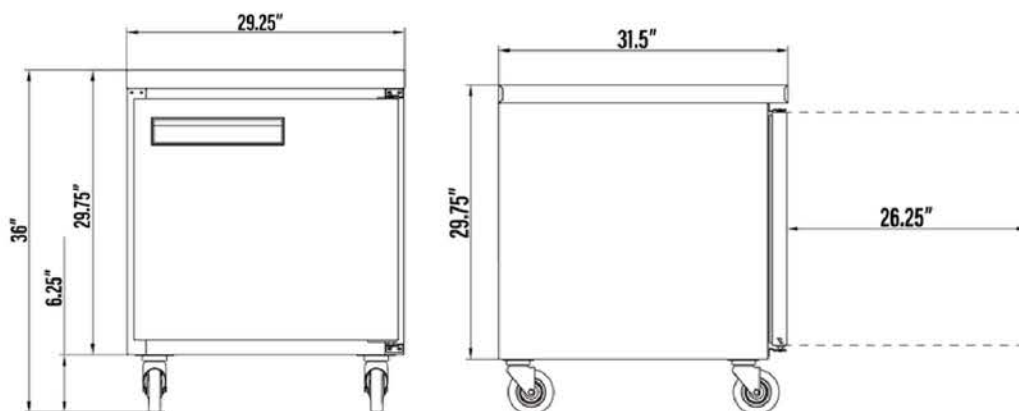
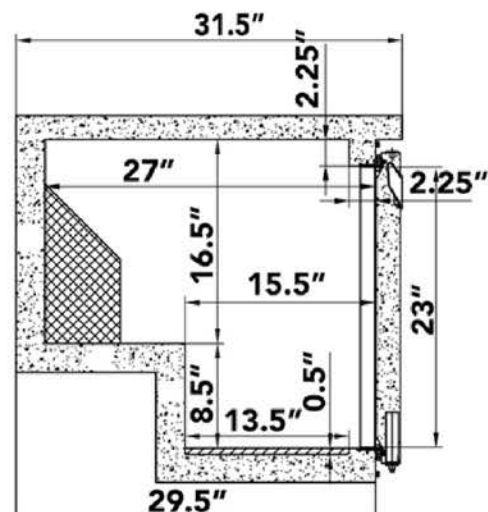

NEMA 5-15P



Intertek



**NEW AIR**

\*La conception et les spécifications peuvent changer sans préavis pour améliorer le produit

SERVICE CLIENT



1-800-567-3620



NEWAIRREFRIGERATION.CA

