

# NPT-036-MSA

# NEW AIR

## TABLE DE PRÉPARATION RÉFRIGÉRÉE POUR SALADES ET SANDWICHS

Idéal pour les restaurants, les cafétérias et les espaces de transformation des aliments



## CARACTÉRISTIQUES

Intérieur et extérieur en acier inoxydable

Contrôleur numérique arrière

Compresseur monté à l'arrière

Portes à fermeture automatique  
avec fonction de maintien ouvert

Tablettes robustes ajustables

Plats en plastique 1/6 transparents inclus

Planche à découper de 9"



# SPÉCIFICATIONS

Capacité (Pied Cu.)	11.47
Capacité (Litres)	324.79 L
Dimensions extérieures (po)	36" × 33 1/8" × 43 5/8"
Dimensions intérieures (po)	31 7/8" × 20" × 23"
Poids net (kg/lbs)	97.5 kg / 215 lbs
Nbre de porte(s)	2
Température (°C)	0.5 à 5°C
Température ambiante	25°C
Humidité ambiante	55%
Réfrigérant (sans CFC)	R290
Ampérage (A)	2.4 A
Voltage (V)	115V / 60Hz
Type de prise	NEMA 5-15P

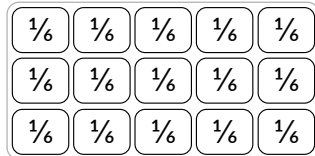
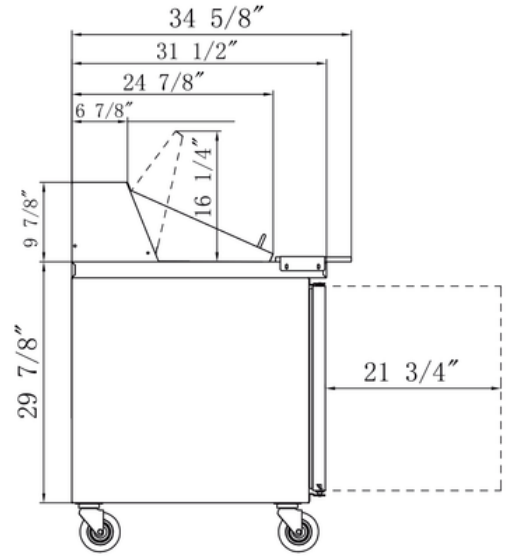

15 x Plats 1/6



NEMA 5-15P



Intertek

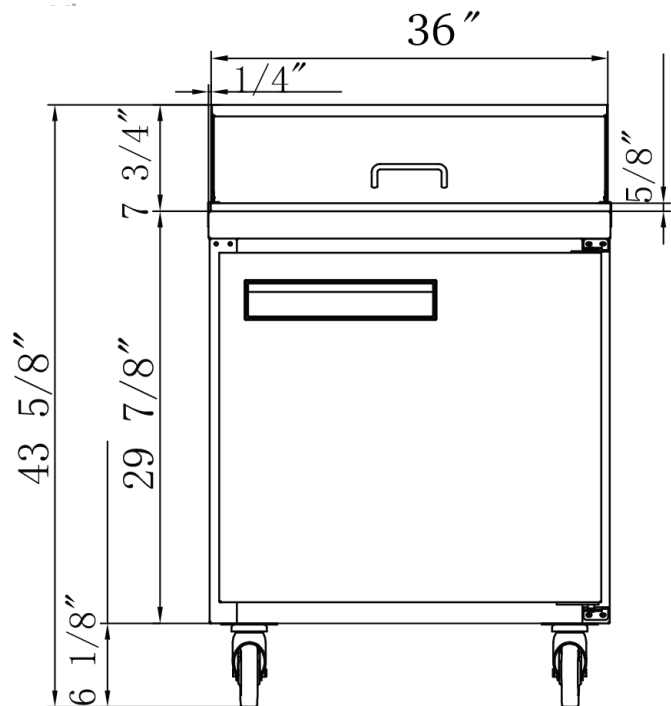

**NEW AIR**

\*La conception et les spécifications peuvent changer sans préavis pour améliorer le produit

SERVICE CLIENT



1-800-567-3620



NEWAIRREFRIGERATION.CA

